

Semi Flush Miniature Pressure Sensor



Features

- ➔ Operating from -40 to +125°C
- ➔ Thin film technology
- ➔ Semi flush miniature sensor
- ➔ High natural frequency up to 120kHz

Applications

- ➔ Automotive - on vehicle
- ➔ Aerospace
- ➔ Research laboratory
- ➔ Automation & Robotics

The PSF160 series is designed for highly dynamic pressure measurements. Thanks to a semiflush construction, the pressure diaphragm is exposed, in direct contact with the medium, with reduced dead volume. Being all titanium, it is compatible with most media including corrosive fluids used in industry. Unamplified (mV/V output) or equipped with the latest signal conditioning technologies from EFE (0-5 and 0.5-4.5Vdc outputs), it is able to measure very dynamic pressure spikes. Its thin film sensitive element ensures high performances and stability over wide temperature range. Models with built-in electronics (power supply : 8-30Vdc), being low consumption (< 10mA) and with high bandwidth capabilities are particularly adapted to embedded applications.

Technical specifications

Pressure ranges (FS)	-1/+4bar ; -1/+9bar ; 5bar ; 10bar ; 20bar ; 40bar ; 70bar ; 250bar ; -14.5/+60PSI ; -14.5/+140PSI ; 70PSI ; 150PSI ; 300PSI ; 500PSI ; 1000PSI ; 3000PSI
Type	Absolute ; Gage
Type (for ranges > 40 bar)	Sealed Gage
Safe overload	150% FS
Burst pressure	300% FS
Output impedance	> 3000 Ohms typ.
Input impedance	> 3500 Ohms typ.
Power supply	5 to 15Vdc
Consumption	< 10mA
Insulation	> 1000 MOhms under 50Vdc at ambient temperature
Output at -100%FS (only for ± range)	Proportional to +100%FS
Output at 0%FS	0mV/V

Technical Specifications

Output at 100%FS	1.5mV/V nom.
Zero and sensitivity settings tolerances	±3% FS
Non linearity and hysteresis combined	±0.25% FS typical (±0.35% FS max.)
Non repeatability	±0.02% FS typ.
Compensated temperature range	0 to +60°C Option : -25 to +85°C ; -25 to +125°C ; -40 to +125°C
Operating temperature range	-40 to +125°C
Combined thermal zero & sensitivity shifts	±0.02% FS/°C
Constant acceleration in linear vibrations	± 0.02% FS/g (frequency 20-2000Hz, 50g max.)
Mechanical shock	100g ½ sinus 1ms
Electrical protection	Protected against polarity inversion
EMC protection	Compliant to EN61000
Electrical connection	AWG26, Viton Jacketed Shielded Cable Ø3mm, 4 wires
Mechanical connection	M10x1-4h male semi-flush with integrated O-ring
Material(s) of wetted parts	Titanium TA6V (3.7165)
Weight	< 20g without cable
Enclosure protection	IP65 for absolute & sealed gage version

Codification

Semi Flush Miniature Pressure Sensor	PSF16	1	T	10bar	A	17	08/1m	A	3	1
Output Signal										
	mV/V		1							
Material										
	Titanium		T							
Range										
	Example			10bar						
Type										
	Absolute				A					
	Gage				G					
	Sealed Gage				SG					
Mechanical connection										
	M10x1-4h male semi-flush with integrated O-ring					17				
Electrical connection										
	AWG26, Viton Jacketed Shielded Cable Ø3mm, 4 wires						08/1m			
Compensated temperature range										
	0 to +60°C							A		
	-25 to +85°C							B		
	-25 to +125°C							C		
	-40 to +125°C							D		
Non linearity and hysteresis combined										
	±0.25% FS typical (±0.35% FS max.)								3	
Combined thermal zero & sensitivity shifts										
	±0.02% FS/°C									1

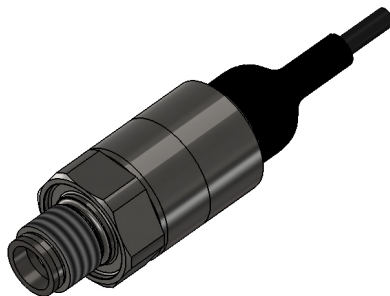
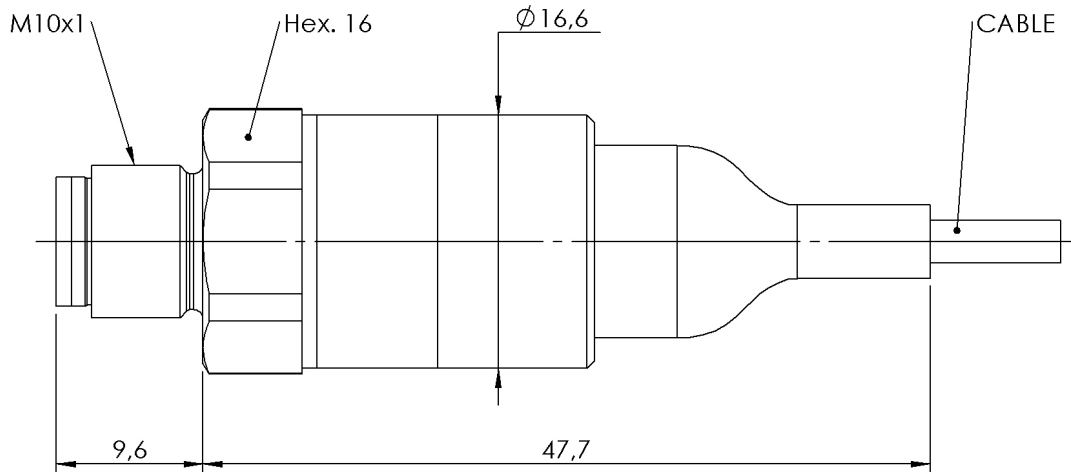

DIMENSIONS : mm

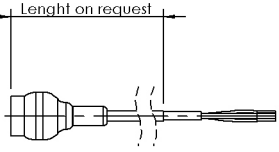
	#26 AWG, 4 CONDUCTOR SHIELDED VITON CABLE		
	mV/V OUTPUT	CONDUCTOR	
	+ EXCITATION	RED	
	+ SIGNAL	GREEN / YELLOW	
	- SIGNAL	WHITE	
	- EXCITATION	BLUE / BLACK	
	SENSOR HOUSING	SHIELD	

Agent :



E.F.E.
 L'ESSOR FRANCAIS ELECTRONIQUE
 16 Rue Porte a Bateaux - 27540 Ivry-la-Bataille - FRANCE
 Tel : 33 (0)2 32 22 35 05 - Fax : 33 (0)2 32 36 93 08
www.efe-sensor.com - infos@efe-sensor.com